

Maszt wykonać z profilu A4363(52x63) lub A4721(57x73) produkcji Huty Kęty

Bardzo dobry maszt i bom można wykonać z bambusa lub zużytych masztów od desek.

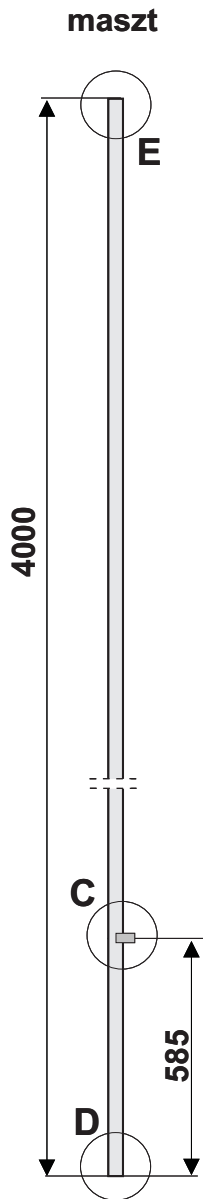

D mocowanie masztu do dna

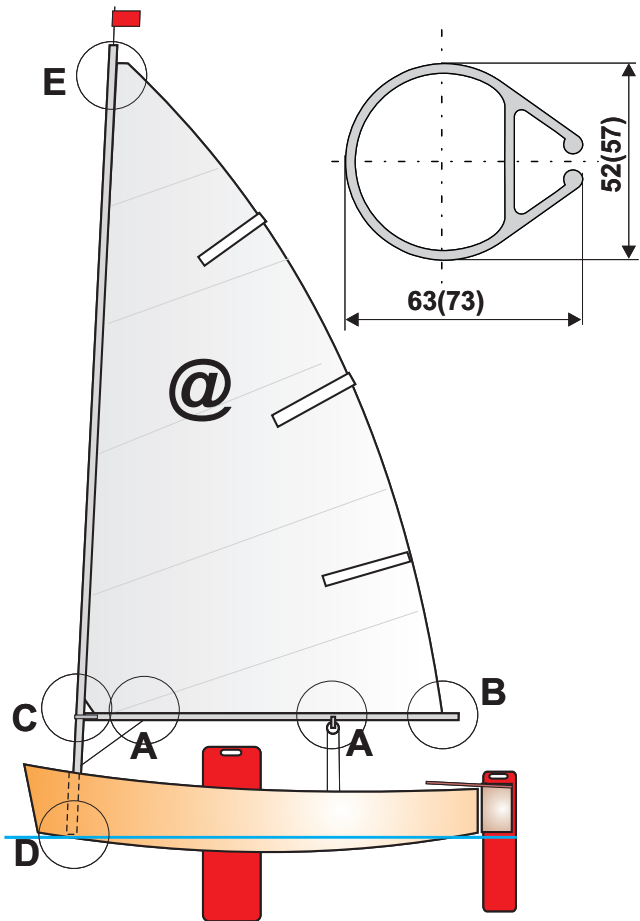
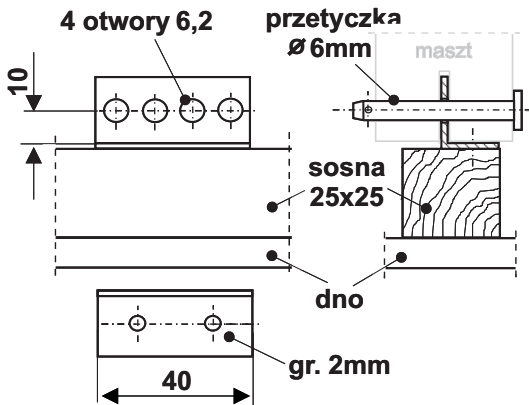

D stopa masztu

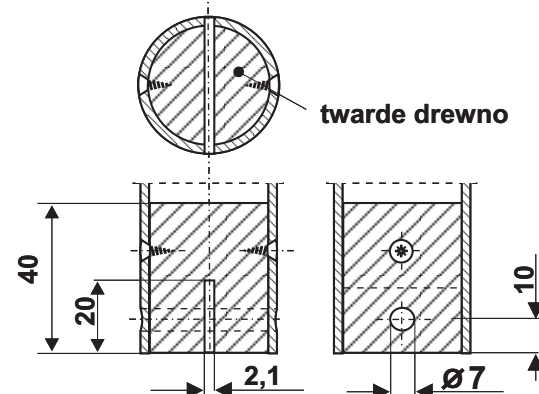

C Mocowanie pięty bomu do masztu

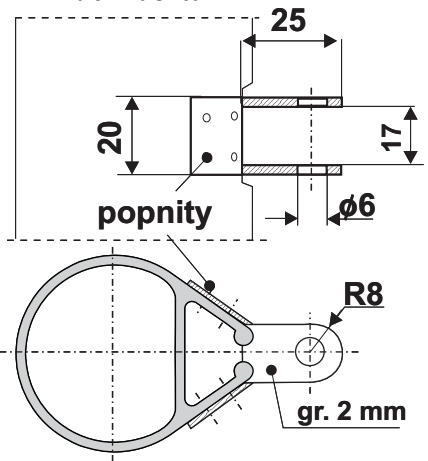

E Okucie topu masztu /wymiary dla profilu 4363/

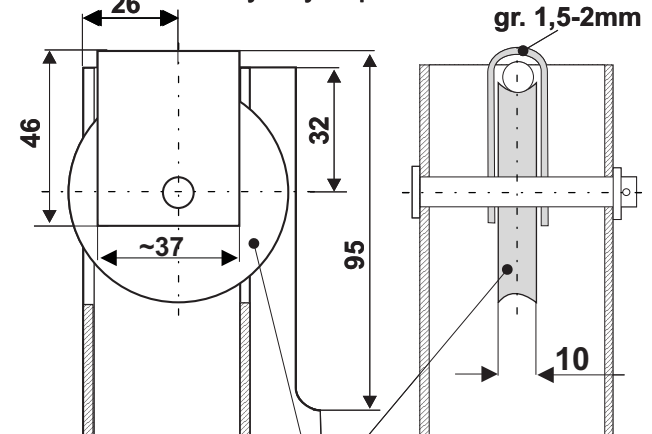

A przelotka kuta lub blaszana

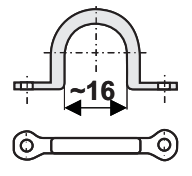

B zakończenie noku bomu

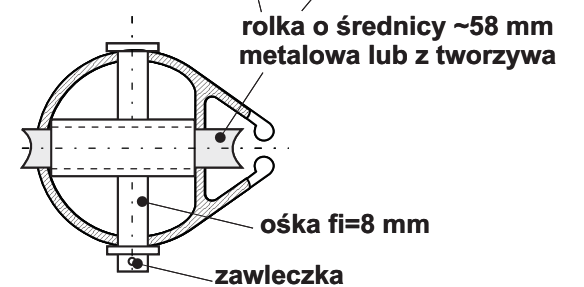
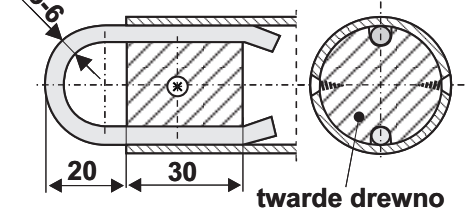

26-08-2013
Ostatnia zmiana